

**INSTRUCTIONS FOR INSTALLING REPLACEMENT ASSEMBLIES IN A NATIONAL VENDORS[®]
 MODULINE SERIES 21CE OR A CROWN SEVENTY TWO[®] SERIES 21CE-72 ELECTRIC CANDY
 MERCHANDISER CONTROL BOX ASSEMBLY**

**CHECK THE PARTS RECEIVED IN THE KIT WITH THE PARTS LIST
 IN THESE INSTRUCTIONS. IF ANY PARTS ARE MISSING, CONTACT
 NATIONAL VENDORS' PARTS DEPARTMENT IMMEDIATELY.**

I. GENERAL INFORMATION

Under a policy now in effect, National Vendors is making the Assemblies listed below available to the operators of 21CE and 21CE-72 Merchandisers. The operator may procure and install these Assemblies in any 21CE or 21CE-72 he has purchased from National Vendors.

All Moduline Series 21CE and some Crown Seventy Two Series 21CE-72 Merchandisers are equipped with Control Box Assemblies which are sealed with a Label which reads: "This unit has been factory checked. Warranty void if cover has been removed." Because the Cover must be removed to perform the operations given in these instructions, National Vendors will not void the Warranty on any equipment still in Warranty if a replacement is made with parts obtained from National Vendors and if the installation of the parts is made in accordance with the procedures given in these Instructions.

Although replacement of all the units listed below are covered in these Instructions, only follow those procedures pertinent to the Assembly which has been ordered for replacement. Before attempting to make a replacement, carefully read the applicable procedures and then perform the work.

CAUTION

1. **Unpack and handle the replacement Assembly with care. DO NOT bend, distort, damage, or scartch any of the printed circuit paths that may be part of the individual replacement Assembly.**
2. **When removing a defective Assembly or installing a replacement Assembly, use care to prevent distortion or damage to the Control Box Assembly components which may not be defective. Do not cut the insulation on the wires in the box.**
3. **Check all Connectors to be sure they are properly located and securely seated after making a replacement.**

The Assemblies covered by these instructions are:

Part Number	Description
121-6015	Diode Board Assembly * * *
127-6209	Relay Module Assembly
9900-019	No.8-32 x 3/8" RH Machine Screw (3 required) * * *
127-6010	23-Pole Relay Assembly * * *
127-6001	Installation Instructions * * *

NOTE

All Control Boxes used in the 21CE Moduline Merchandisers and some of the Control Boxes used in 21CE-72 Crown Seventy Two Series Merchandisers, were when the Merchandisers were built, equipped with a Relay Unit Assembly and a separate Relay Unit Circuit Board Assembly. When a replacement of either of these Units is required, Relay Module Assembly, part number 127-6209, which replaces both Units, is to be installed in the Control Box.

The three Relays in the replacement Relay Module Assembly are individually replaceable. The part number for the "Sync Relay" is 404-1168; for the "Anti-jackpot Relay" 404-1168; and for the "Time Delay Relay" 127-6202.

Figure 1 shows an illustration of each of the three Assemblies.

I. PRELIMINARY INSTRUCTIONS

- A. Disconnect the Merchandiser Service Cord Plug from the wall receptacle.
- B. Open the Cabinet Door.
- C. Remove all the Harness Plugs from the Receptacles on the Control Box.

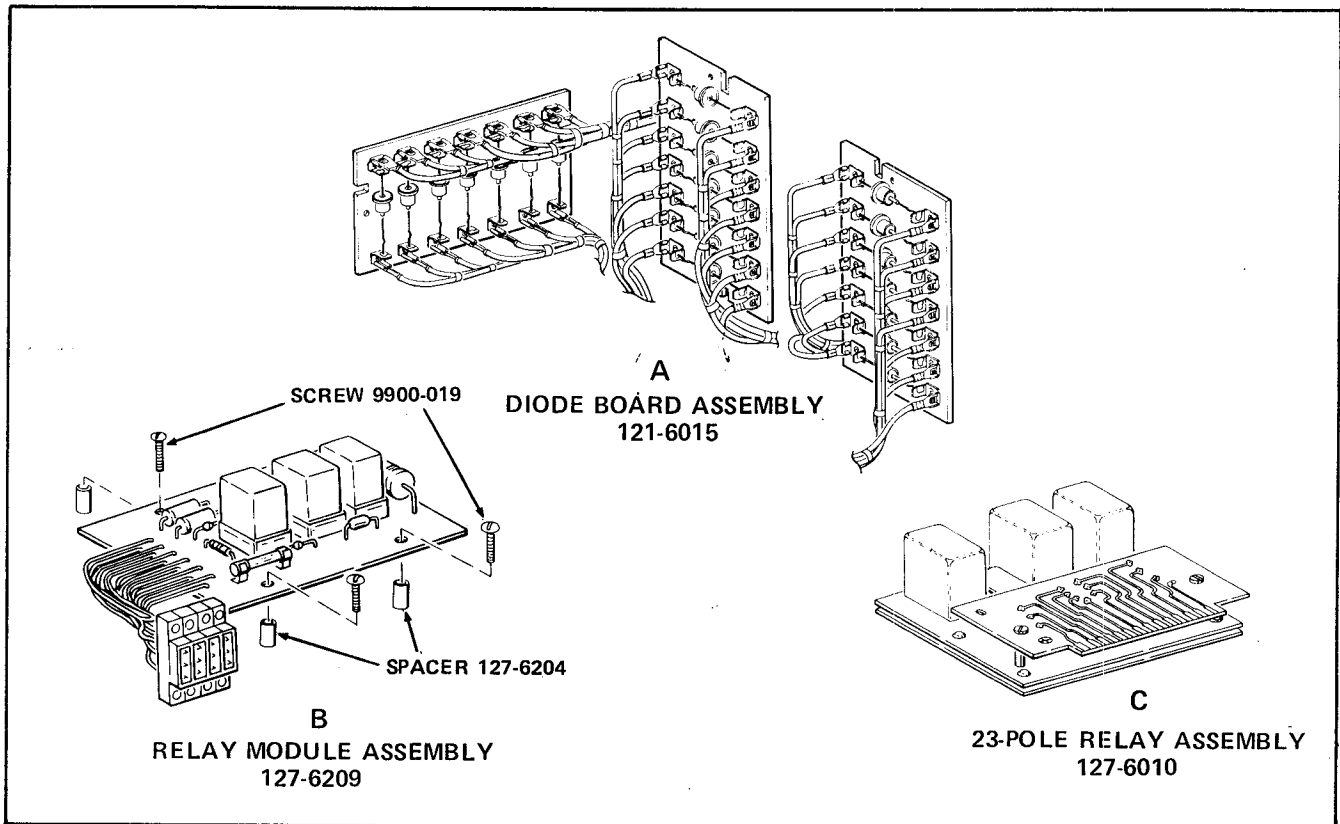

FIGURE 1

- D. Remove the 2-wing nuts from the Studs which attach the front of the Control Box to the Merchandiser.
- E. Support the Control Box from beneath and slide the Control Box back to free the Studs from the lip of the Cabinet Center Pan.
- F. Rotate the Control Box downward until it clears the lower edge of the lip.
- G. Slide the Box forward off its rear Mounting Bracket and out of the Merchandiser.
- H. Place the Control Box on a flat surface Cover side up.
- I. Remove the No.8-32 x 1/4" Round head Self-tapping Screw which attaches the (red) Control Box Cover.
- J. Remove the Cover. See Introduction for information about Warranty Label removal.
- K. Perform the replacement of the defective Assembly as given in the appropriate following procedure.
- L. Install the Control Box Cover and attach it with the Screw removed in step J.

- M. Install the Control Box Assembly in the Merchandiser.
- N. Close the Cabinet Door.
- O. Attach the Service Cord Plug to the wall receptacle.
- P. Thoroughly test vend the Merchandiser before returning it to service.

III. TO REPLACE THE DIODE BOARD ASSEMBLIES

The Diode Board Assemblies, Item A in Figure 1, are part number 121-6015.

Three Diode Board Assemblies are used in each Merchandiser. These instructions cover the replacement of all three Assemblies. If only one of the three Assemblies requires replacement, follow only those steps which pertain being the specific Board Assembly being replaced.

Figure 2 shows the location of the three Diode Board Assemblies in the Control Box. Two of the Boards are attached with No.6-32 x 5/16" Round head Self-tapping Screws. The third Board is attached with a No.6-32 x 3/8" Round head Machine Screw

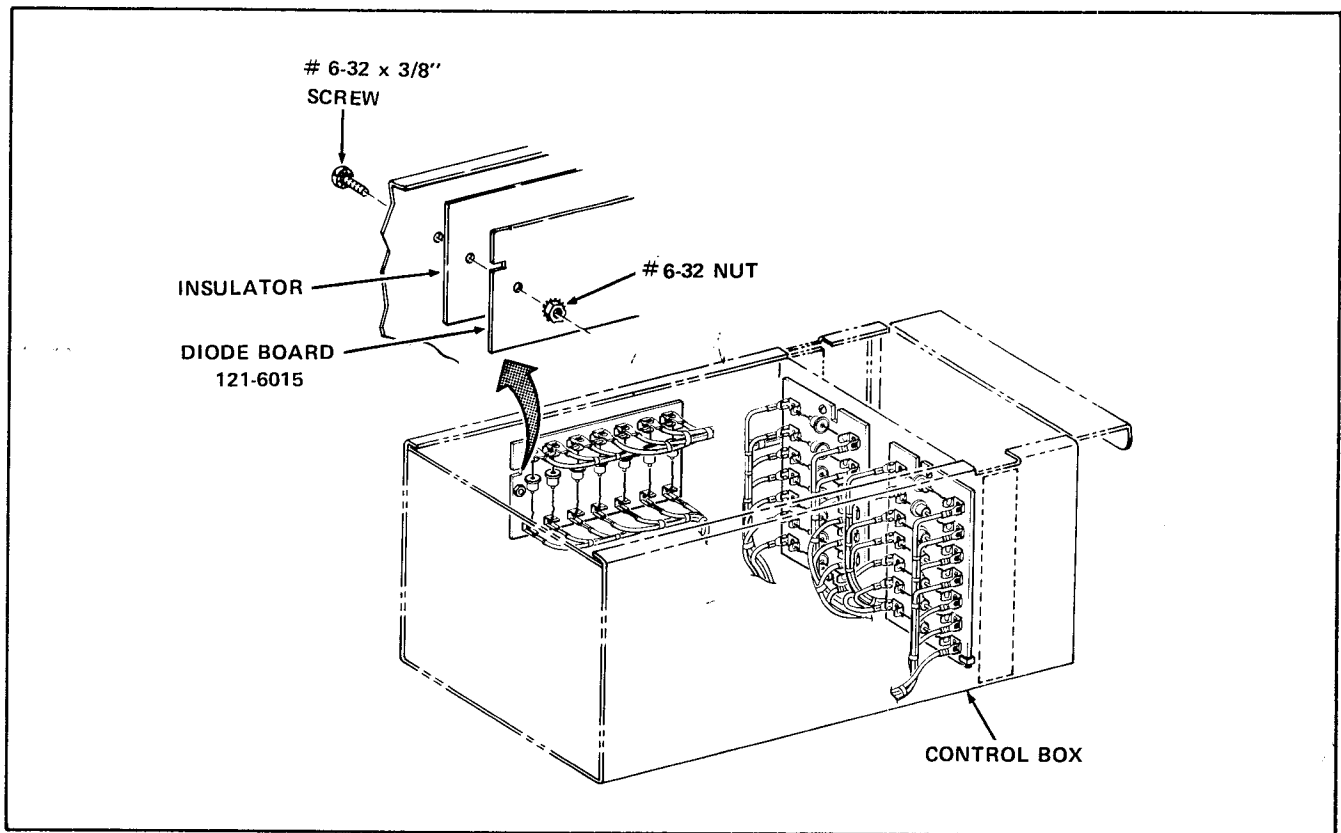

FIGURE 2

with Lockwasher and a No.6-32 Nut with Lockwasher. The instructions given for the installation use the type of attaching hardware for the location reference of the specific diode Board Assembly being replaced.

A. To Replace The Diode Board Assembly Attached With The Screw And Nut:

1. Remove the Screw and Nut which attaches the Board Assembly.
2. Slide the Board off its mounting tabs and out of the Control Box as far as the wire lengths will permit.
3. To provide additional wire slack, the Diode Board which is next in line to the Board removed in step A-2, may be removed. This Board is attached to the Control Box Divider with a No.6-32 x 5/16" Round head Self-tapping Screw.
4. One at a time remove the quick-disconnectors from the terminals on the defective Board Assembly and connect each wire to the comparable terminal on the replacement Diode Board Assembly.

CAUTION

The wires to the replacement Board must be connected in accordance with the applicable view in Figure 3 which shows the proper wiring of all three of the Diode Board Assemblies.

5. After the replacement Board has been correctly wired:
 - a. If the second Board was removed per step A-3, install the second Board. Be sure the Board is backed by an Insulator; that the bottom end of the Board and Insulator is hooked in the appropriate tabs on the Divider; and that the No.6-32 x 5/16" Round head Self-tapping Screw attaches both the Board Assembly and the Insulator to the Divider. Figure 2 shows the proper position this Board Assembly is to be in when installed.
 - b. Install the replacement Diode Board Assembly. Be sure the Board is backed by an Insulator; that the one end of the Board and Insulator is hooked in the tabs which are on the side and toward the front of the Control Box; and that the No.6-32 x 3/8" Screw and the No.6-32 Nut attaches both the Board and the Insulator to the Control Box. See Figure 2.

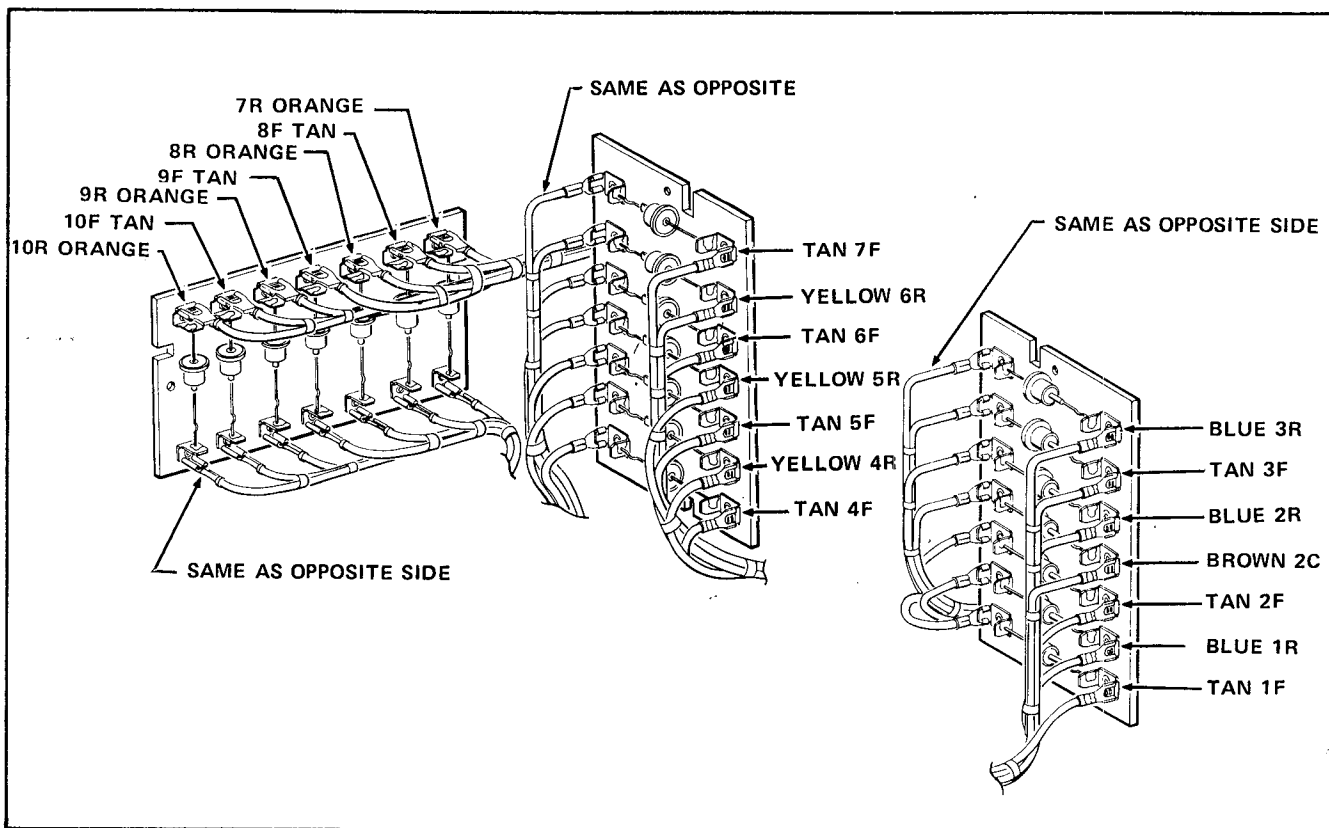

FIGURE 3

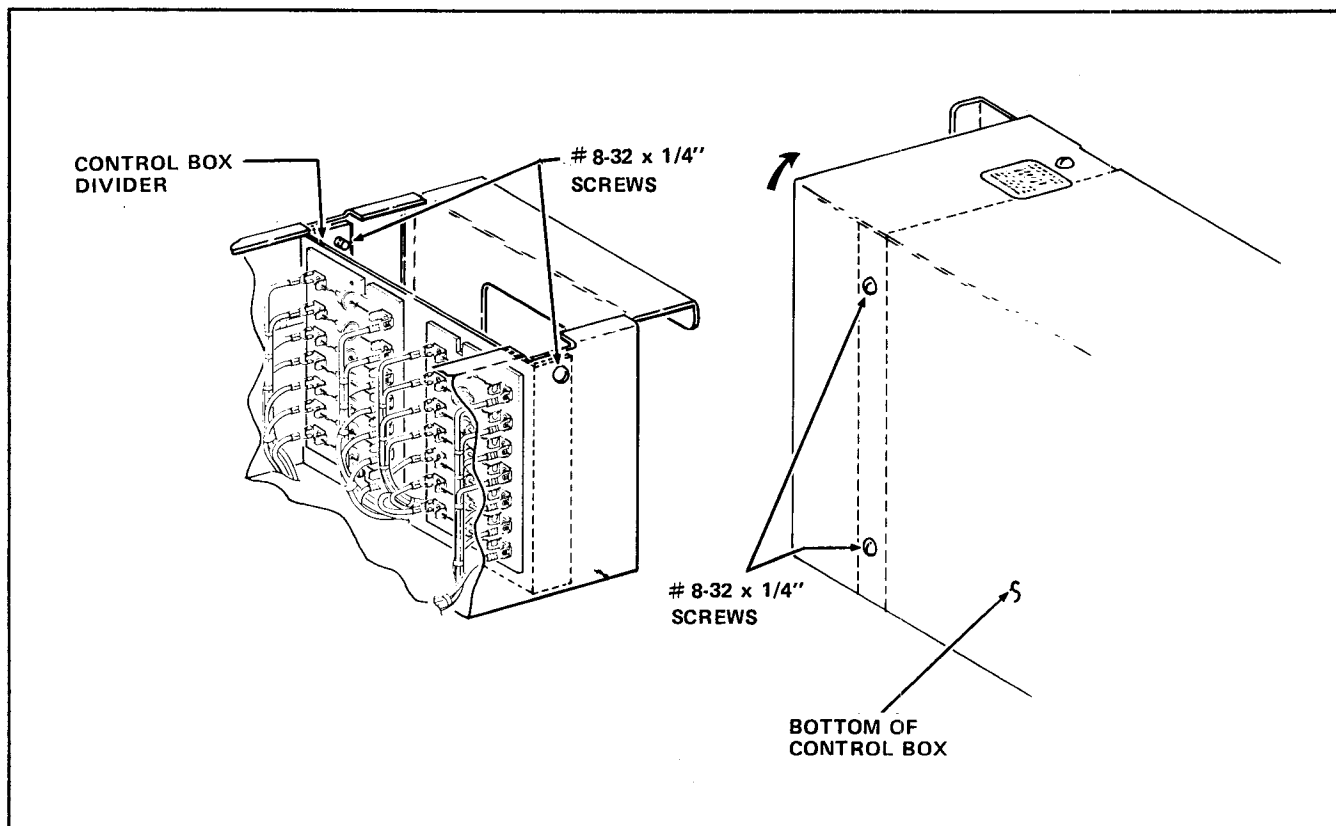

FIGURE 4

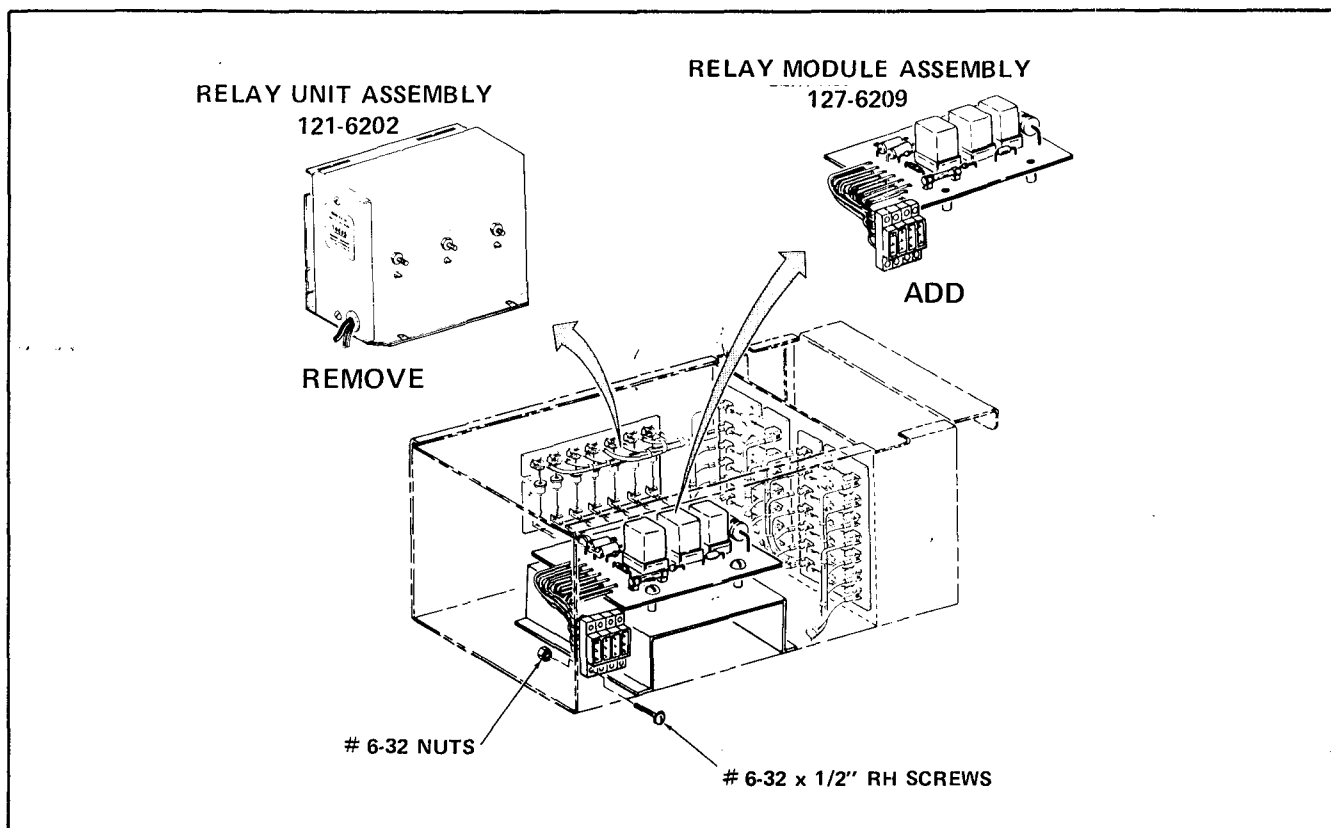

FIGURE 5

B. To Replace The Diode Board Assemblies Attached With The Self-Tapping Screw.

1. Remove the four No.8-32 x 1/4" Round head Self-tapping Screws which attach the Control Box Divider. See Figure 4.
2. Pull the Divider as far out of the Control Box as the wiring will allow.
3. Remove the Self-tapping Screw which attaches the defective Board Assembly.
4. Pull the Board off its mounting tabs and out of the Control Box as far as the wire lengths will permit.
5. One at a time remove the quick-disconnectors from the terminals on the defective Board Assembly and connect each wire to the comparable terminal on the replacement Diode Board Assembly.
6. After the replacement Board has been correctly wired, attach the replacement Assembly to the Divider. Be sure the Board is backed by an Insulator; that the bottom end of the Board and Insulator is hooked in the tabs on the Divider; and that the No.6-32 x 5/16" Round head Self-tapping Screw attaches both the Board Assembly and the Insulator to the Divider. Figure 2 shows the proper position these Boards are to be in when installed.
7. Move the Divider back into place. Be sure no wires are caught below the bottom angle on the Divider.
8. Install the four No.8-32 x 1/4" Screws removed in step B-1.

IV. TO REPLACE THE RELAY UNIT ASSEMBLY AND THE RELAY UNIT CIRCUIT BOARD ASSEMBLY WITH A RELAY MODULE ASSEMBLY

CAUTION

The wires to the replacement Board must be connected in accordance with the applicable view in Figure 3 which shows the proper wiring of all three of the Diode Board Assemblies.

The Relay Module Assembly is part number 127-6209, Item 3 in Figure 1. The Relay Module Assembly replace the combination of the Relay Unit Circuit Board Assembly.

A. To Remove The Combined Relay Unit Assembly And The Unit Circuit Board Assembly.

1. Remove the Connector from the Relay Unit Circuit Board Assembly. See Figure 5.
2. Remove the four No.6-32 x 1/2" Round head Machine Screws with Lockwashers and the four No.6-32 Nuts with Lockwashers which attach the Connector on the Relay Unit Assembly Harness to the Control Box.
3. Remove the three No.8-32 Nuts with Lockwashers which attach the Relay Unit Assembly to the Control Box. See Figure 5.
4. Remove the combined Assembly of the Relay Unit Assembly and the Relay Unit Circuit Board Assembly from the Control Box.

B. To Install The Relay Module Assembly:

1. Screw the three Spacers, part number 127-7204, onto the three Studs in the Relay Cover Assembly. These are the Studs from which the No.8-32 Nuts were removed in step IV-A-3. See Figure 5.
2. Position the replacement Relay Module Assembly on the three Spacers and attach the Assembly with the three No.8-32 x 3/8" RH Machine Screws, part number 9900-019.
3. Install the Relay Module Assembly Harness Connector and attach it to the Control Box with the four Screws and Nuts removed in step IV-A-2.
4. Attach the Connector, removed in step IV-A-1, onto the Relay Module Assembly.

V. TO REPLACE THE 23-POLE RELAY ASSEMBLY

The 23-Pole Relay Assembly is part number 127-6010, Item C in Figure 1.

CAUTION

The 23-Pole Relay Assembly can be damaged if not properly handled. Carefully unpack the replacement Relay and handle it carefully during the entire replacement procedure.

To replace the 23-Pole Relay Assembly:

A. When a 23-Pole Relay Assembly requires replacement, one of two possible conditions can exist: The Control Box may be equipped with (1) a Relay Unit Assembly and Relay Unit Circuit Board Assembly, or (2) with a Relay Module Assembly.

1. If the Control Box is equipped with a Relay Unit Assembly and Relay Unit Circuit Board Assembly, follow procedure IV-A and remove the combined Assembly from the Control Box.
2. If the Control Box is equipped with a Relay Module Assembly, remove the Assembly by reversing steps 2 through 5 in procedure IV-B.

B. Lay the Control Box on its side, the side which has no Connectors in it. See Figure 6.

C. Remove the two No.8-32 x 3/8" Pan Head Screws with Lockwashers and the No.8-32 Nuts with Lockwashers which attach the Relay Cover Assembly to the Control Box and remove the Relay Cover Assembly.

D. Remove the two No.8-32 x 3/8" Pan Head Screws with Lockwashers which attach the defective 23-Pole Relay Assembly.

E. Install the replacement 23-Pole Relay Assembly and attach it with the two Screws removed in step C.

F. Install the Relay Unit Assembly Harness Connector and attach it to the Control Box with the four No.6-32 x 1/4" Round Head Machine Screws with Lockwasher and the four No.6-32 Nuts with Lockwashers.

G. Install the Relay Cover Assembly and attach it with the two Screws and Nuts removed in step C. Be sure no wires are caught under the flanges of the Cover Assembly.

H. 1. If a combined Assembly of a Relay Unit Assembly and a Relay Unit Circuit Board Assembly is to be reinstalled in the Control Box, reverse procedure IV-A.

2. If a Relay Module Assembly is to be reinstalled in the Control Box, follow steps 2 through 5 in procedure IV-B.

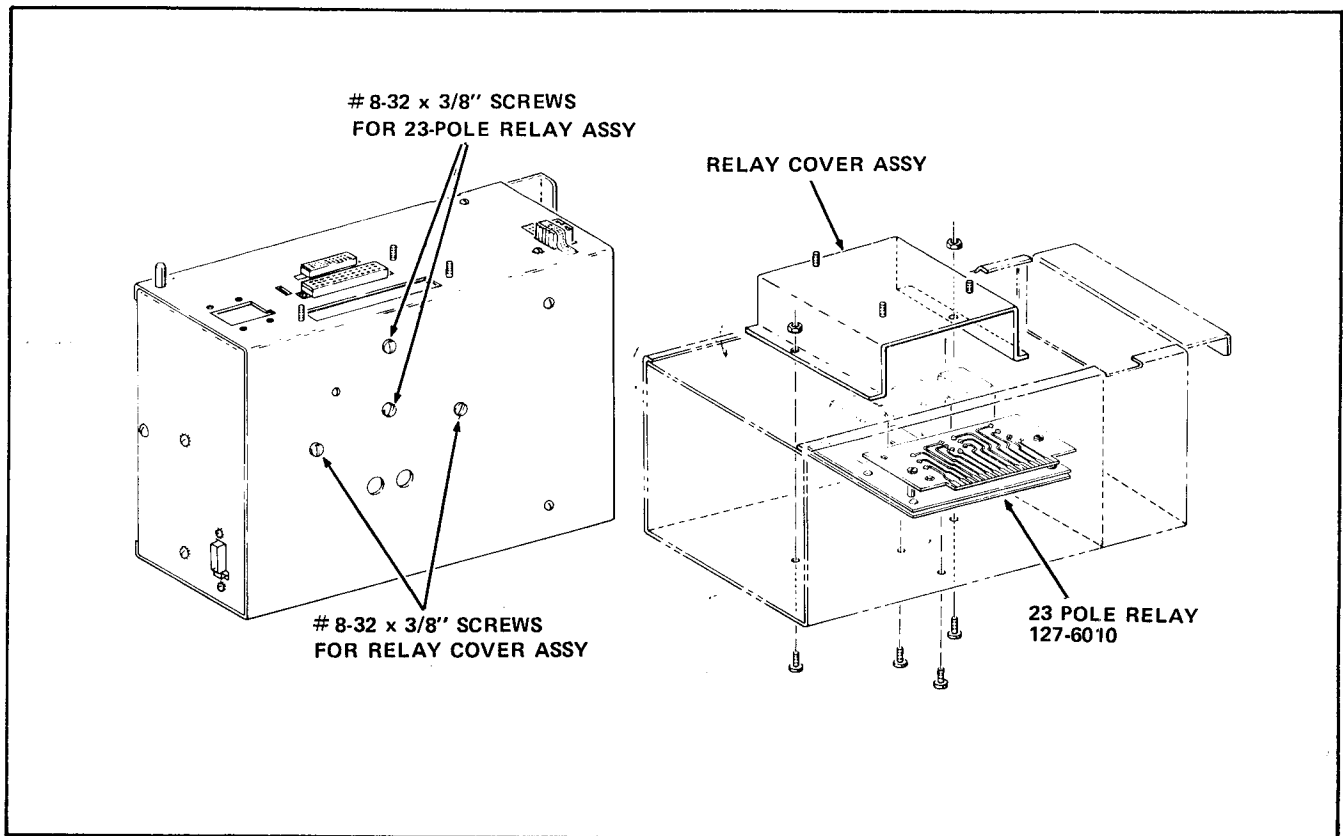

FIGURE 6